

www.worky-italy.com

 BRACCI

 ARMS

 BRAS

 ARME

 BRAZOS

WORKY®

SB



 I bracci articolati SB sono autoportanti tramite una struttura esterna a pantografo con molle di richiamo e frizioni regolabili. La cappetta è fatta di materiale plastico con maniglia di movimentazione e serrandina di parzializzazione. I bracci SB sono idonei al posizionamento a parete, a soffitto o su prolunga a bandiera ed hanno tutto il diametro interno libero da ostruzioni per una portata ottimale. La ralla in acciaio e i tubi in lamiera zincata ne fanno uno strumento per l'utilizzo quotidiano in ambienti industriali.

 The articulated SB arms are self-supporting through an external pantograph structure with recessed springs and adjustable clutches. The hood is made of plastic material with handle for easy movement together with a partitioning shutter. The SB arms are suitable for wall or ceiling mounting as well as on prolongations and have any internal diameter free from obstructions for an optimal flow. Steel swivel and galvanized sheet metal tubes make it an everyday tool for industrial use.

 Les bras articulés SB sont autoportants grâce à une structure externe à pantographe avec des ressorts en retrait et des embrayages réglables. La hotte est en plastique avec poignée pour manipuler et partitionner l'aspiration. Les bras SB sont adaptés pour un positionnement au murs, des plafonds ou des prolongations et ont un diamètre interne libre d'obstructions pour un débit optimal. Les tubes en tôle galvanisée et un roulement en acier font un outil de tous les jours à usage industriel.

 Die gelenkigen SB-Arme sind durch eine äußere Pantograf Struktur mit eingelassenen Federn und verstellbaren Kupplungen selbsttragend. Die Haube ist aus Kunststoff, mit Griff und Absperrlappe imbegriffen. Die SB-Arme sind für Wand-, Decken- oder Verlängerungen geeignet und haben alle Innendurchmesser frei von Hindernissen für optimalen Durchfluss. Stahlflansch und verzinkten Blechrohre machen es zu einem alltäglichen Werkzeug für den industriellen Einsatz.

 Los brazos articulados SB son autoportantes a través de una estructura externa de pantógrafo con resortes empotrados y embragues ajustables. La boca está hecha de material plástico con cierre manual para particionar el caudal aspirante. Los brazos SB son adecuados para el montaje a pared, techo o extensión a bandera y tienen todo el diámetro interno libre de obstrucciones para un flujo óptimo. El rodamiento en acero y los tubos de chapa galvanizada lo convierten en una herramienta diaria para uso industrial.

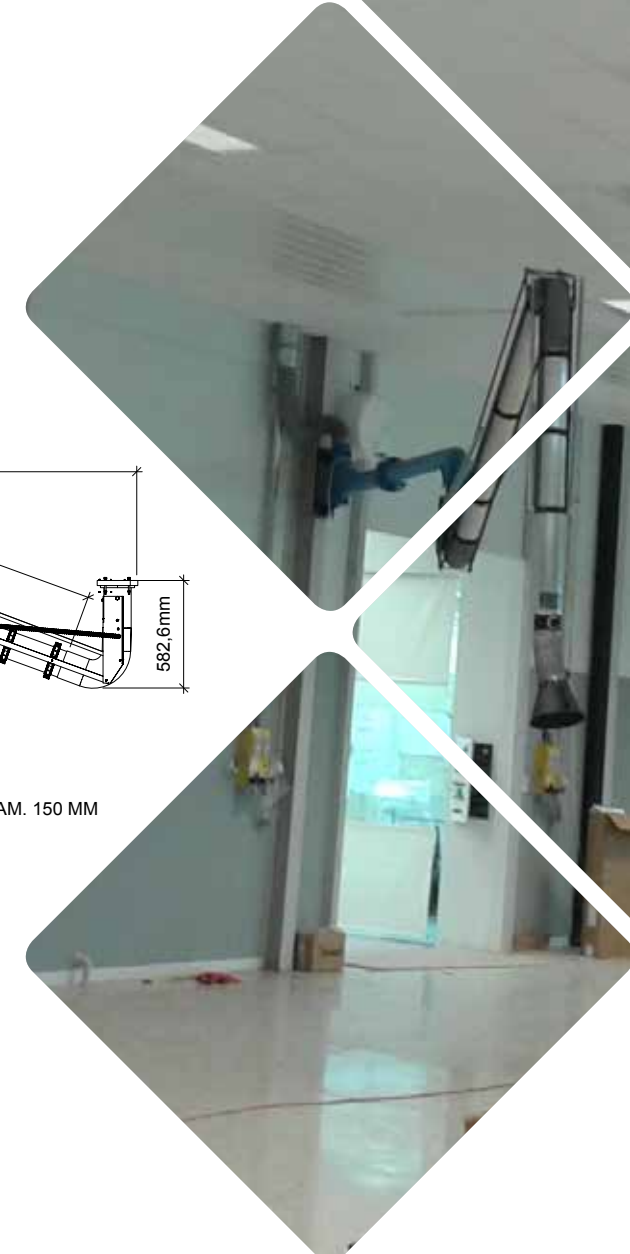
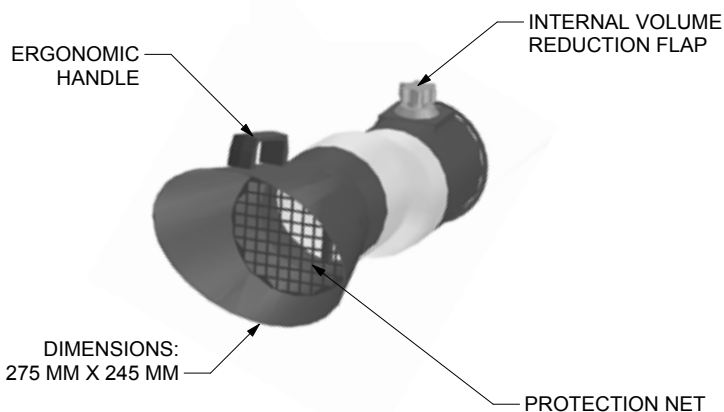
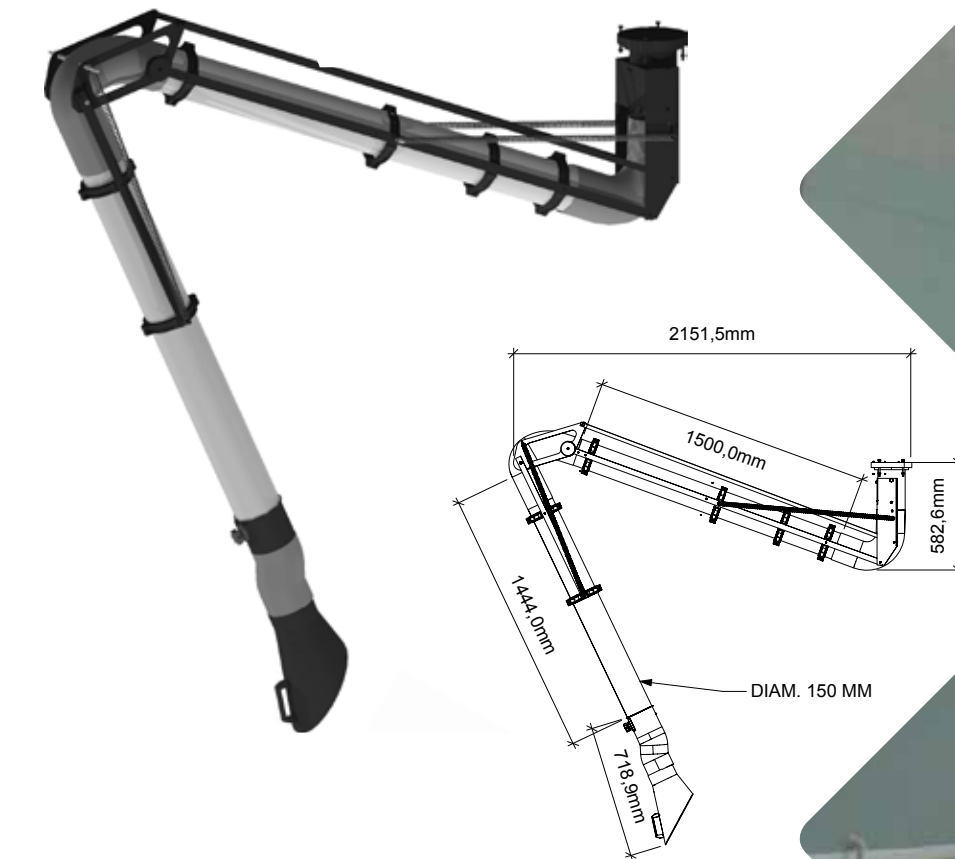



SB



SB	L.	ø mm
SB2	2 m	150
SB3	3 m	150
SB4	4 m	150
SB5	5 m	150

 Braccio autoportante diametro 150 mm per aspirazione fumi di saldatura.

 Self supporting arm diameter 150 mm for welding fume extraction.

 Bras articulé de 150 mm de diamètre pour aspiration des fumées de soudure.

 Schweissrauch-Absaugarm DN 150 mm.

 Brazo autoportante diámetro 150 mm para humos de soldadura.

SBB



SBB	L 1	L 2	ø mm
SBB6	2 m	4 m	150
SBB7	3 m	4 m	150
SBB8	4 m	4 m	150
SBB9	4 m	5 m	150

 Braccio autoportante diametro 150 mm con prolunga per aspirazione fumi di saldatura.

 Self supporting arm diameter 150 mm with extension for welding fume extraction.

 Bras articulé de 150 mm de diamètre, avec rallonge pour aspiration des fumées de soudure.

 Schweissrauch-Absaugarm mit Verlängerung DN 150 mm.

 Brazo autoportante con extensión diámetro 150 mm para humos de soldadura.

SBA



SBA	L.	ø mm	Kw/HP	SBA	L.	ø mm	Kw/HP
SBA21	2 m	150	0,75/1	SBA41	4 m	150	0,75/1
SBA215	2 m	150	1,1/1,5	SBA415	4 m	150	1,1/1,5
SBA31	3 m	150	0,75/1	SBA42	4 m	150	1,5/2
SBA315	3 m	150	1,1/1,5	SBA51	5 m	150	0,75/1
				SBA515	5 m	150	1,1/1,5

 Braccio autoportante diametro 150 mm per aspirazione fumi di saldatura, completo di aspiratore.

 Self supporting arm diameter 150 mm for welding fume extraction, complete with fan.

 Bras articulé de 150 mm de diamètre, pour aspiration des fumées de soudure, avec ventilateur d'extraction.

 Schweissrauch-Absaugarm DN 150 mm ausgestattet mit Ventilator.

 Brazo autoportante diámetro 150 mm para humos de soldadura completo de aspirador.

SBBA



SBBA	L.	ø mm	Kw/HP	SBBA	L.	ø mm	Kw/HP
SBBA615	6 m	150	1,1/1,5	SBBA815	8 m	150	1,1/1,5
SBBA62	6 m	150	1,5/2	SBBA82	8 m	150	1,5/2
SBBA715	7 m	150	1,1/1,5	SBBA915	9 m	150	1,1/1,5
SBBA72	7 m	150	1,5/2	SBBA92	9 m	150	1,5/2

 Braccio autoportante diametro 150 mm con prolunga e aspiratore per fumi di saldatura.

 Self supporting arm diameter 150 mm with extension and fan for welding fume extraction.

 Bras articulé de 150 mm de diamètre, avec rallonge et ventilateur pour aspiration des fumées de soudure.

 Schweißrauch-Absaugarm DN 150 mm mit Verlängerung und Ventilator.

 Brazo autoportante con extensión diámetro 150 mm y aspirador para humos de soldadura.

SBKL



SBKL	V	W
SBKL	12	50

 Kit luce a 12V - 50W, per braccio di saldatura completo di interruttore e trasformatore.

 12V - 50W light kit for welding fume extraction arm complete with switch and transformer.

 Kit d'éclairage 12V - 50W pour bras d'aspiration des fumées de soudure complet avec interrupteur et transformateur.

 12V - 50W Beleuchtungskit für Schweißrauchabsaugarm komplett mit Schalter und Transformator.

 Brazo autoportante con extensión diámetro 150 mm y aspirador para humos de soldadura.



SBAN



SBAN	L.	ø mm	SBAN200	L.	ø mm
SBAN1	1 m	150	SBAN1-200	1 m	200
SBAN2	2 m	150	SBAN2-200	2 m	200
SBAN3	3 m	150	SBAN3-200	3 m	200
SBAN4	4 m	150	SBAN4-200	4 m	200

 Prolunga a bandiera con mensola pivotante per bracci di saldatura.

 Flag extension with pivoting bracket for welding fumes extraction arms.

 Extension murale avec console pivotante pour bras de aspiration des fumées de soudure.

 Verlängerung mit Schwenkhalterung für Schweißrauchabsaugarme.

 Extensión con estante pivotante para brazos de soldadura.

SPARK





SPARK	Kw	HP	L.	ø mm	Kg. carb
SPARK-315	1,1	1,5	3 m	150	4,5
SPARK-32	1,5	2	3 m	150	4,5
SPARK-415	1,1	1,5	4 m	150	4,5
SPARK-42	1,5	2	4 m	150	4,5
SPARK-515	1,1	1,5	5 m	150	4,5
SPARK-52	1,5	2	5 m	150	4,5

 Kit murale di aspirazione e filtrazione per fumi di saldatura composto da braccio, elettroaspiratore e filtro murale modello SFTC con 4,5 Kg. di carbone attivo.

 Stationary filtering and extracting kit for welding fumes, complete with fan, self supporting arm and filter SFTC with 4,5 Kg of activated carbons.

 Système fixe pour l'aspiration et la filtration des fumées de soudure avec ventilateur bras articulé et filtre SFTC avec 4,5 Kg de charbon actif.

 Feste Schweißrauchfilteranlage, komplett mit Ventilator, Absaugarm und SFTC Filter mit 4,5 Kg Aktivkohlen.

 Sistema fijo para aspiración y filtración de humo de soldadura, completo de aspirador, brazo articulado y filtro SFTC con 4,5 Kg. de carbón activado.

SPARK10





SPARK10	Kw	HP	L.	ø mm	Kg. carb
SPARK10-315	1,1	1,5	3 m	150	10
SPARK10-32	1,5	2	3 m	150	10
SPARK10-415	1,1	1,5	4 m	150	10
SPARK10-42	1,5	2	4 m	150	10
SPARK10-515	1,1	1,5	5 m	150	10
SPARK10-52	1,5	2	5 m	150	10

 Kit murale di aspirazione e filtrazione per fumi di saldatura composto da braccio, elettroaspiratore e filtro murale modello SFTC10 con 10 Kg. di carbone attivo.

 Stationary filtering and extracting kit for welding fumes, complete with fan, self supporting arm and filter SFTC10 with 10 Kg of activated carbons.

 Système fixe pour l'aspiration et la filtration des fumées de soudure avec ventilateur bras articulé et filtre SFTC10 avec 10 Kg de charbon actif.

 Feste Schweißrauchfilteranlage, komplett mit Ventilator, Absaugarm und SFTC10 Filter mit 10 Kg Aktivkohlen.

 Sistema fijo para aspiración y filtración de humo de soldadura, completo de aspirador, brazo articulado y filtro SFTC10 con 10Kg de carbón activado.

SFTC



SFTC	max m³/h	effic.	Kg. carb.	in/out
SFTC5	2000	95%	4,5	200 mm
SFTC10	2000	95%	10	200 mm

 Filtro a parete per fumi di saldatura completo di flange Ø 200 mm, portata massima di 2.000 mc/h, efficienza di filtrazione fino al 95% completo di filtro a carboni attivi.

 Wall mounted filtering unit for welding fumes, complete with flanges Ø200mm. Max airflow 2.000 mc/h, filtering efficiency up to of 95%, complete with activated carbon filter.

 Système mural pour la filtration des fumées de soudure avec entrée et sortie de Ø200mm. Débit max 2.000 mc/h. Efficacité de filtration jusqu'a 95%, complété de filtre à charbon actif.

 Wandmontierte Schweissrauchfilteranlage, komplett mit Ein-Ausgangflanschen DN 200 mm. Förderleistung 2.000 m³/h, mit Aktivkohlenfilter. Abscheidegrad 95%.

 Sistema fijo a pared de filtración de humo de soldadura, completo de bocas de entrada y salida de Ø200 mm. Caudal máx. 2.000 m³/h. Eficiencia de filtración de 95%.

SFTCPACK



SFTCPACK	max m³/h	nr. filt	effic.	Kg. carb.
SFTCPACK5	2000	4	95%	4,5
SFTCPACK10	2000	4	95%	10

 Set di 4 filtri di ricambio per SFTC, sia in configurazione standard che in quella con 10 Kg. di carbone attivo.

 Set of 4 spare filters for SFTC, both in standard configuration and with 10 Kg of activated carbon.

 Kit de 4 filtres de rechange pour le SFTC, en configuration standard et avec 10 kg de charbon actif.

 Satz von 4 Ersatzfiltern für SFTC, sowohl in Standardausführung als auch mit 10 kg Aktivkohle.

 Conjunto de 4 filtros de repuesto para SFTC, tanto en configuración estándar como con 10 Kg de carbón activado.

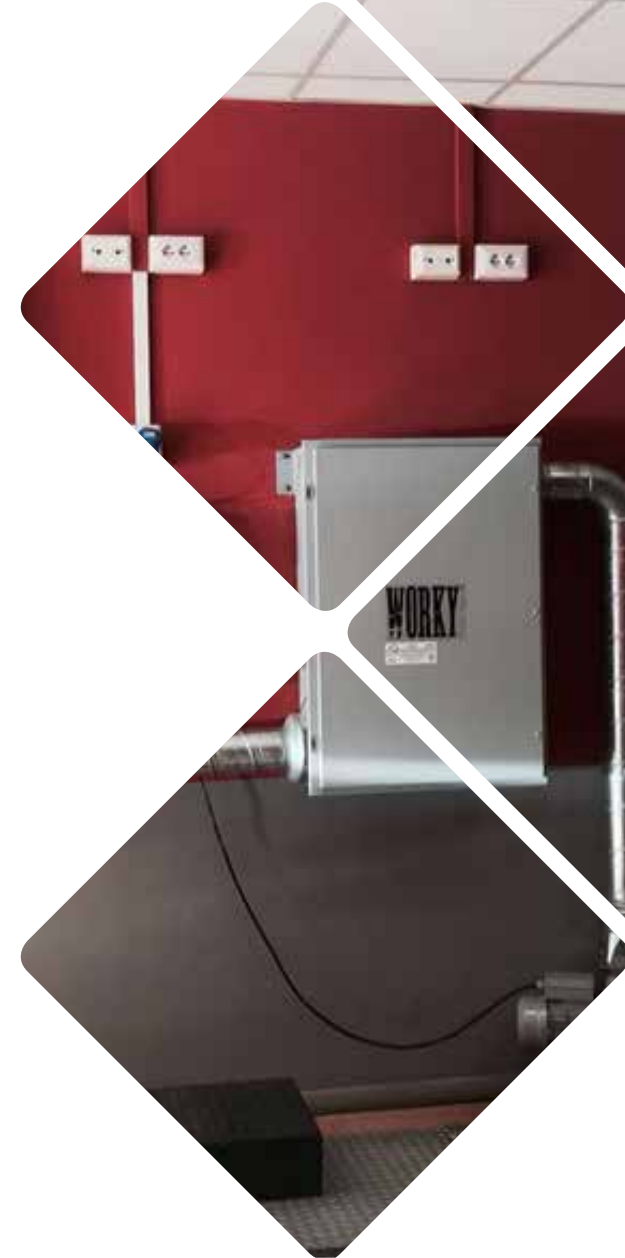

SBF160



SBF160	L.	ø mm	Valv.
SBF160-3	3 m	160	-
SBF160-4	4 m	160	-
SBF160-3V	3 m	160	✓
SBF160-4V	4 m	160	✓

 Braccio autoportante flessibile diametro 160 mm per aspirazione fumi di saldatura.

 Self supporting flexible arm diameter 160 mm for welding fume extraction.

 Bras articulé en flexible de 160 mm de diamètre pour aspiration des fumées de soudure.

 Flexibler Schweissrauch-Absaugarm DN 160 mm.

 Brazo autoportante flexible en diámetro 160 mm para humos de soldadura.

SBBF



SBBF	L 1	L 2	ø mm	Valv.	ø out
SBBF6	2 m	4 m	160	-	150
SBBF7	3 m	4 m	160	-	150
SBBF8	4 m	4 m	160	-	150
SBBFV6	2 m	4 m	160	✓	150
SBBFV7	3 m	4 m	160	✓	150
SBBFV8	4 m	4 m	160	✓	150

 Braccio flessibile autoportante diametro 160 mm con prolunga per aspirazione fumi di saldatura.

 Self supporting flexible arm diameter 160 mm with extension for welding fume extraction.

 Bras articulé flexible de 160 mm de diamètre avec rallonge pour aspiration des fumées de soudure.

 Flexibler Schweissrauch-Absaugarm DN 160 mm mit Verlängerung.

 Brazo flexible autoportante diámetro 160 mm con extensión para humos de soldadura.

SBFA





SBFA	L.	ø mm	Kw/HP	Valv.	ø out
SBFA31	3 m	160	0,75/1	-	160
SBFA315	3 m	160	1,1/1,5	-	160
SBFA32	3 m	160	1,5/2	-	200
SBFA41	4 m	160	0,75/1	-	160
SBFA415	4 m	160	1,1/1,5	-	160
SBFA42	4 m	160	1,5/2	-	200

 Braccio autoportante flessibile diametro 160 mm per aspirazione fumi di saldatura, completo di aspiratore.

 Self supporting flexible arm diameter 160 mm for welding fume extraction, complete with fan.

 Bras articulé en flexible de 160 mm de diamètre, pour aspiration des fumées de soudure, avec ventilateur d'extraction.

 Flexibler Schweissrauch-Absaugarm DN 160 mm ausgestattet mit Ventilator.

 Brazo autoportante en flexible diámetro 160 mm para humos de soldadura completo de aspirador.

SBBFA



SBBFA	L.	ø mm	Kw/HP	Valv.
SBBFA615	6 m	160	1,1/1,5	-
SBBFA62	6 m	160	1,5/2	-
SBBFA715	7 m	160	1,1/1,5	-
SBBFA72	7 m	160	1,5/2	-
SBBFA815	8 m	160	1,1/1,5	-
SBBFA82	8 m	160	1,5/2	-

 Braccio autoportante diametro 160 mm con prolunga e aspiratore per fumi di saldatura.

 Self supporting arm diameter 160 mm with fan and extension for welding fume extraction.

 Bras articulé de 160 mm de diamètre, avec rallonge pour aspiration des fumées de soudure, avec ventilateur d'extraction.

 Schweißrauch-Absaugarm DN 160 mm mit Ventilator und Verlängerung.

 Brazo autoportante diámetro 160 mm con aspirador y extensión para aspirar humos de soldadura.

SBF160-KL



SBF160-KL	V	W
SBF160-KL	12	50

 Kit luce a 12V per braccio composto da trasformatore, cablaggio e lampada da 50W.

 12V light kit for arm complete with transformer, cables and 50W lamp.

 Kit d'éclairage 12V pour bras composé de transformateur, câblage et lampe 50W.

 12V Beleuchtungs-kit für Arm bestehend aus Transformator, Verdrahtung und 50W Lampe.

 Kit de luces 12V para brazo compuesto por transformador, cableado y lámpara de 50W.

SBF-WB / CB

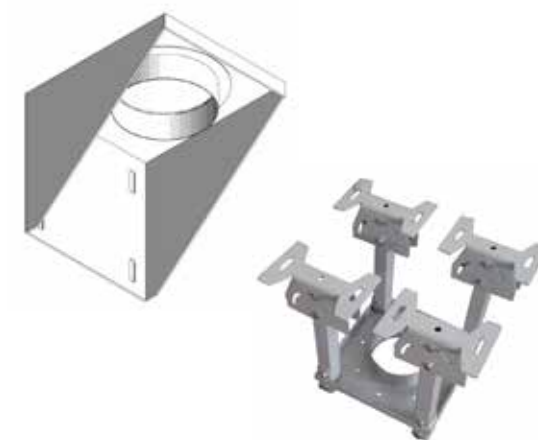



SBF160	Appl.
SBF160-WB	Wall / Parete
SBF160-CB	Ceiling / Soffitto

 Staffa per fissare a parete o a soffitto i bracci flessibili SBF160

 Bracket for fixing the SBF160 flexible arms to the wall or ceiling.

 Support pour la fixation des bras flexibles SBF160 au mur ou au plafond.

 Halterung zur Befestigung der flexiblen Arme SBF160 an Wand oder Decke.

 Soporte para fijar los brazos flexibles SBF160 a pared o al techo.

SMBR



SMBR	L.	ø mm	Valv.
SMBR75-1105	1105 mm	75	✓
SMBR100-1185	1185 mm	100	✓

 Braccio autoportante rigido in alluminio con snodi in polipropilene per applicazioni da laboratorio.

 Self supporting aluminum arm with polypropilene junctions and conical hood. Suitable for laboratory applications.

 Bras autoportant en aluminium avec jonctions en polypropylène et hotte conique. Convient aux applications de laboratoire.

 Selbsttragender Alu-Absaugarm mit Polypropylen-Verbindungen und konischer Haube. Geeignet für Laboranwendungen.

 Brazo de aluminio autoportante con uniones de polipropileno y campana cónica. Apto para aplicaciones de laboratorio.

SBMINI



SBMINI	L.	Flex	ø mm	Valv.	ø out mm
SBMINI100-1.2	1,1 m	-	100	✓	100
SBMINI120-1.2	1,1 m	-	120	✓	120
SBMINI150-1.1	1,1 m	-	150	✓	150

 Minibraccio autoportante per aspirazione fumi di saldatura da completare con tubo flessibile.

 Self-supporting mini arm for welding fumes extraction, to be completed with flexible hose.

 Mini bras autoportant pour aspiration des fumées de soudure, à compléter avec le flexible.

 Selbsttragender Miniarm für Schweißrauchabsaugung. Flexibler Schlauch nicht inbegriffen.

 Mini brazo autoportante para la extracción de humos de soldadura para completar con una manguera flexible.

SB200



SB200	L.	ø mm	Kw/HP	Valv.	ø out
SB2003	3 m	200	-	-	200
SB2004	4 m	200	-	-	200
SB2005	5 m	200	-	-	200

 Braccio autoportante rigido diametro 200 mm per aspirazione fumi di saldatura, completo di flangia a muro.

 Self supporting arm diameter 200 mm for welding fume extraction, complete with wall bracket.

 Bras articulé de 200 mm de diamètre, pour aspiration des fumées de soudure, avec console murale.

 Schweißrauch-Absaugarm DN 200 mm ausgestattet mit Wankonsole

 Brazo autoportante diámetro 200 mm para humos de soldadura completo de soporte a pared.

GTA



GTA	Ø	GTA	Ø
GTA-100	100 mm	GTA-160	160 mm
GTA-120	120 mm	GTA-180	180 mm
GTA-130	130 mm	GTA-200	200 mm
GTA-150	150 mm	GTA-250	250 mm

 Tubo flessibile in alluminio aggraffato resistente fino a 300°C ed estensibile da 1 a 3 mt di lunghezza totale. Adatto ai collegamenti e a raccordare gli arrotolatori alla tubazione rigida.

 Rugged aluminum hose resistant up to 300° C and extensible from 1 to 3 mt of total length. Suitable for connecting the hose reels to rigid piping.

 Tuyau robuste en aluminium résistant jusqu'à 300° C et extensible de 1 à 3 mètres de longueur totale. Convient pour les connexions en général et pour connecter les enrouleurs à la tuyauterie rigide.

 Aluminiumschlauch, beständig bis 300° C und erweiterbar von 1 bis 3 mt Gesamtlänge. Geeignet für Verbinden der Aufrollern mit starren Rohrleitungen.

 Manguera de aluminio resistente hasta 300° C y extensible de 1 hasta 3 m de longitud total. Adecuado para conectar los enrolladores a tuberías rígidas.

GTP



GTP	Ø	L.	GTP	Ø	L.
GTP-100	100 mm	10 m	GTP-160	160 mm	10 m
GTP-125	125 mm	10 m	GTP-200	200 mm	10 m
GTP-130	130 mm	10 m	GTP-250	250 mm	10 m
GTP-150	150 mm	10 m	GTP-300	300 mm	10 m

 Tubazione flessibile resistente fino a 110°C realizzata con tessuto in poliammide spalmato in PVC sui due lati e spirale incorporata di filo di acciaio armonico.

 Flexible hose up to 110° C made of PVC-coated polyamide fabric on both sides and built-in spiral wire of harmonic steel.

 Tuyau flexible jusqu'à 110° C en tissu polyamide revêtu de PVC sur les deux côtés et fil spirale intégré en acier harmonique.

 Flexibler Schlauch bis 110° C aus beidseitig PVC-beschichtetem Polyamidgewebe und eingebautem Spiraldraht aus Stahl.

 Manguera flexible hasta 110° C hecha de tela de poliamida recubierta de PVC en ambos lados y espiral incorporado de acero armónico.



WOLFF

WORKY®

LAVORA CON NOI, AFFIDATI A PERSONE CAPACI DI CREARE UN MONDO NUOVO INTORNO A TE.

WORK WITH US, TRUST IN PEOPLE ABLE TO CREATE A NEW WORLD AROUND YOU.

*TRAVAILLEZ AVEC NOUS, FAITES CONFIANCE A DES PERSONNES CAPABLES DE CREER UN NOUVEAU MONDE, AUTOUR DE VOUS
ARBEITEN SIE MIT UNS, VERLASSEN SIE SICH AN PERSONEN, DIE IN DER LAGE SIND, RUND UM SIE EINE NEUE WELT ZU SCHAFFEN.*

TRABAJA CON NOSOTROS, CONFÍA EN PERSONAS CAPACES DE CREAR UN MUNDO NUEVO A TU ALREDEDOR.

WORKY®

a brand of RO & Co S.p.A.
Via Masaccio, 15 - Z.I. Mancasale
42124 – REGGIO EMILIA (RE) ITALY

Tel. +39-0522-1545193
Fax. +39-0522-1546451

sales@worky-italy.com
vendite@worky-italy.com
www.worky-italy.com

Seguici su / Follow us on:

